

# TANITA

## BODY COMPOSITION ANALYZER BF-350 INSTRUCTION MANUAL



Please read this instruction manual carefully and keep it handy for future reference.

# 1. Contents

GB

<b>1. Contents</b> .....	2
<b>2. Specifications</b> .....	3
<b>3. Important Notes for Users</b> .....	4
■ Caution Symbols .....	4
■ <b>⚠ Warning</b> .....	4
■ <b>⚠ Warning</b> .....	4
■ <b>⚠ Caution</b> .....	4
■ Maintenance .....	5
■ General Instructions for Accurate Measurement .....	5
<b>4. Parts List and Scale Components</b> .....	6
■ Parts List .....	6
■ Scale Components .....	6
■ Display and Keypad .....	7
■ Rear of Unit .....	7
<b>5. Set Up</b> .....	8
■ Power Supply .....	8
■ Leveling the Weighing Platform .....	8
<b>6. Operating Instructions</b> .....	9
■ Body Composition Analysis Mode .....	9
■ Weight Only Mode .....	12
■ BMI Mode .....	12
<b>7. Troubleshooting</b> .....	14
<b>8. Optional Software</b> .....	14

Please read this instruction manual carefully and keep it handy for future reference.



## 2. Specifications







Model		BF-350			
Impedance Measurement	Measurement System	Tetrapolar Bioelectrical Impedance Analysis			
	Measurement Frequency	50kHz			
	Measurement Current	500µA			
	Electrode Material	Pressure Contact Stainless Steel Foot Pads			
	Measurement Style	Between Both Feet			
	Measurement Range	150 ~ 900Ω			
Weight Measurement	Measurement System	Strain Gauge Load Cell			
	Maximum Capacity	200kg	440lb	31st 6lb	
	Minimum Graduation	0.1kg	0.2lb	0.2lb	
Input Items	Gender	Male/Female			
	Body Type	Standard/Athletic			
	Age	7~99 years old/1 year increments			
	Height	90~249cm 1cm increments	3ft~7ft11.5in 0.5in increments		
Output Items	Display	Weight	0~200kg 0.1kg increments	0~440lb 0.2lb increments	0~31st 6lb 0.2lb increments
		Gender	Male/Female		
		Body Type	Standard/Athletic		
		Age	7~99 years old/1 year increments		
		Height	90~249cm 1cm increments	3ft~7ft11.5in 0.5in increments	
		Body Fat %	1.0~75.0% / 0.1% increments		
Display		2 Rows, 5 Digits LCD			
Output Data Interface		RS-232C ( D -sub 9 pins Male Connector)			
Power Source		AC Adapter ( included ) Center Minus			
Rated Power		DC9V 200mA			
Power Consumption		0.7W			
Temperature Range of usage		0~35°C/32~95°F			
Weight of Equipment		7.5kg/16½lb			

# 3. Important Notes for Users

## Caution Symbols

Thank you for purchasing this precision-made Tanita product. For optimum performance and safety, please familiarize yourself with the Caution Symbols below. These symbols are designed to alert the user to potential hazards when using this equipment. Ignoring these Caution Symbols may result in serious injury, or damage to the product.

Please read carefully before proceeding with the Instruction Manual.

	<b>WARNING</b>	This symbol indicates the possibility of death or serious injury if the product is mishandled or instructions are ignored.
	<b>WARNING</b>	This symbol indicates the possibility of electric shock. Please pay special attention to sections bearing this mark.
	<b>CAUTION</b>	This symbol indicates the possibility of physical injury or equipment damage if instructions are ignored.
		This symbol indicates general precautions that should be taken when using this product.

### **WARNING**

- **Individuals with pacemakers or other internal medical devices**

Because Tanita's body composition analyzers send a weak electric current through the body, individuals who have pacemakers or other internal medical devices should not use this product. The weak electric signal could cause such internal devices to malfunction.

- **Cross contamination**

This product must be used in bare feet. Please be sure to clean the weighing platform with appropriate disinfectant after each use. Never pour any liquid directly on the platform, as it may leak into the product and cause it to malfunction. Use a soft cloth and appropriate disinfectant or a neutral detergent to wipe off the platform. Do not wipe with strong chemicals.

### **WARNING**

- **Inserting and removing the power cord**

To reduce the risk of electric shock or damage to the product, never plug in or unplug the

- AC adapter with wet hands.

To avoid risk of fire, make sure the wall outlet is functioning properly. Avoid using multiple outlet extension cords.

### **CAUTION**

- To reduce the chance of inaccurate measurement, place the weighing platform on a firm, level surface.

- To reduce the risk of injury or equipment malfunction, always step on the platform slowly.

- To reduce the risk of fire or damage to the product, use only the Tanita AC adapter provided.

- Do not use the product near equipment such as cellular phones and therapeutic microwave devices. Such equipment could cause the product to malfunction and affect the accuracy of results.



## Maintenance

In order to insure optimum performance from this product, please observe the following instructions:

- Unplug the AC adapter from the wall outlet when the product will not be in use for long periods.
- Always switch off before unplugging the AC adapter from the wall outlet.
- Never disassemble the equipment. Always call your nearest Tanita office or dealer for instructions.
- Do not drop the unit and avoid locations exposed to constant vibration.
- Do not place the unit too close to a heating unit or in direct sunlight.
- Avoid rapid temperature fluctuations.
- Excessive humidity may damage the equipment.
- When transferred to any location where there is a difference of more than 20°C (68°F), wait at least 2 hours before use.



## General Instructions for Accurate Measurement

This product is designed for use by people of normal and athletic build. However, certain individuals may not receive accurate results as they fall outside the population for which Tanita's equations were developed.

- Because this product uses a weak electric current to measure impedance, best results will be achieved when measurements are taken in bare feet.
- Poor contact between the feet and electrodes may produce an error message. Heels should be placed directly on top of the posterior electrodes, while the front part of the foot needs to be in contact with the anterior electrodes. Also make sure the soles of the feet are free of excess dirt, as this may act as a barrier and prevent the mild current from flowing properly.
- Accurate measurement may still be possible even if there are calluses on the soles of the feet or the user is wearing thin nylons. Place 0.5cc (0.017oz) of saline solution or water in the center of each electrode. This will act as a conductor, and may allow the current to pass freely through a thin barrier.
- Keep the electrodes clean by wiping with disinfectant.
- Fluctuations in hydration status (i.e. the water content of body tissues) can affect the results of body composition analysis.
- The user's inner thighs should not be in contact. If they are, a dry towel should be held between the user's legs.

### • Interpretation of results

The data provided by this product, as well as any supplementary information such as diet or exercise programs based on this data, should be interpreted by a licensed professional.

For more information on how to obtain accurate measurements, please refer to the Technical Notes booklet.

# 4. Parts List and Scale Components



## Parts List

### Scale

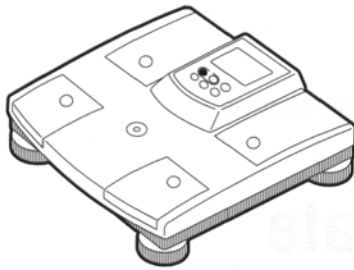

### AC adapter

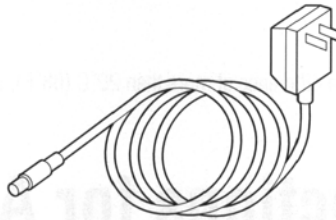

### Dropper



### Warranty and Instructions

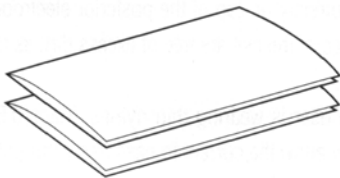

- Instruction Manual
- Technical Notes

## Scale Components – Top View

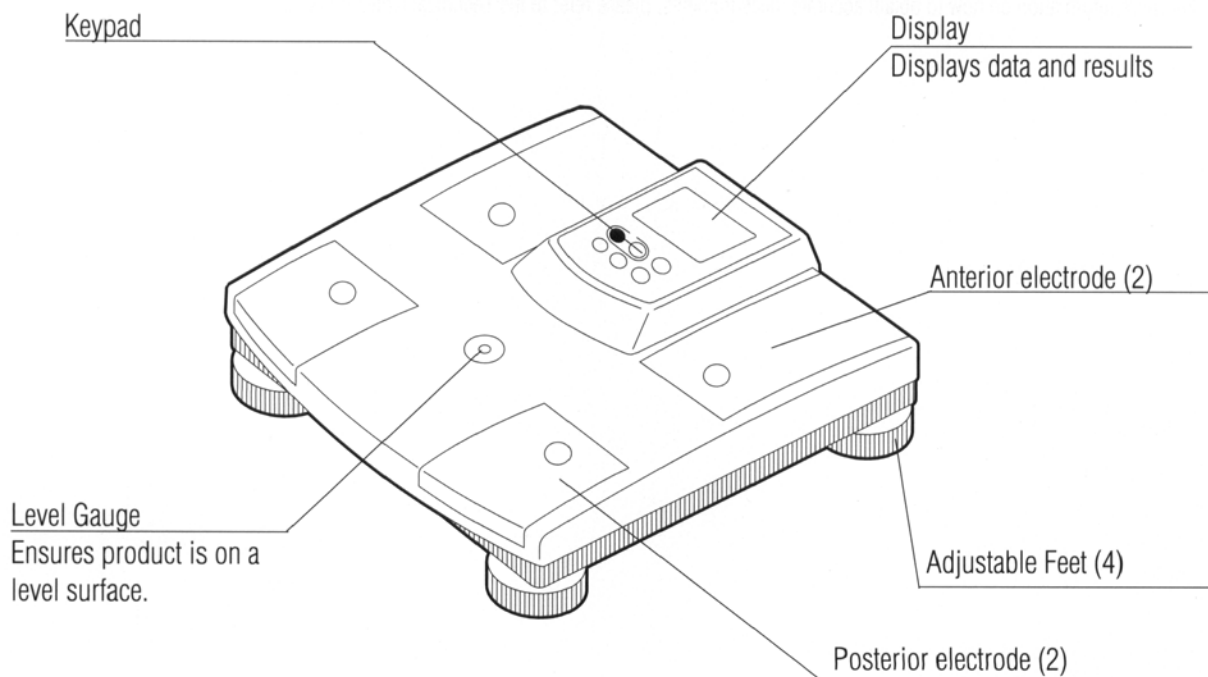

## Display and Keypad

**ON/OFF key**  
Press to turn on and off.

**ZERO/RESET key**  
Use to zero or reset weight values.

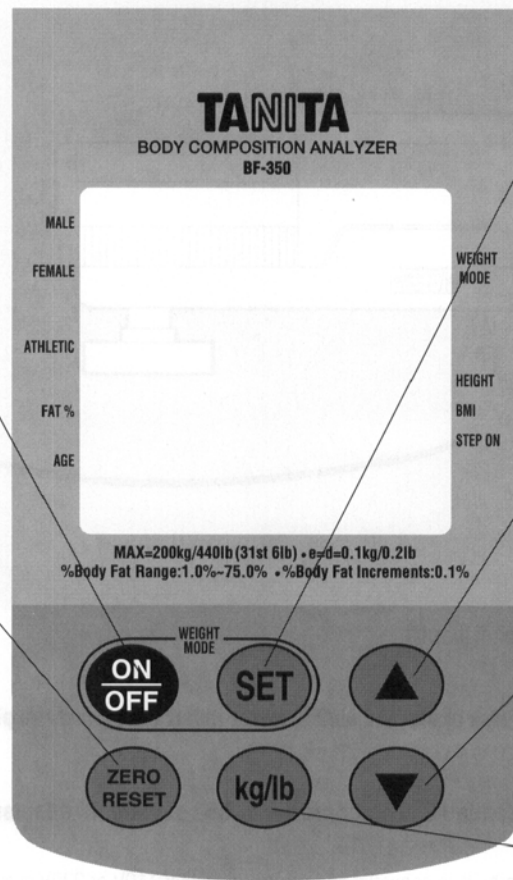

**SET key**  
Confirms data selection. Press simultaneously with the [ON/OFF] key to switch to Weight Only mode. (See p.12.)

**UP Arrow**  
Use to select mode or increase numerical values.

**DOWN Arrow**  
Use to select mode or decrease numerical values.

**kg/lb key**  
Changes measurement units

## Rear of Unit

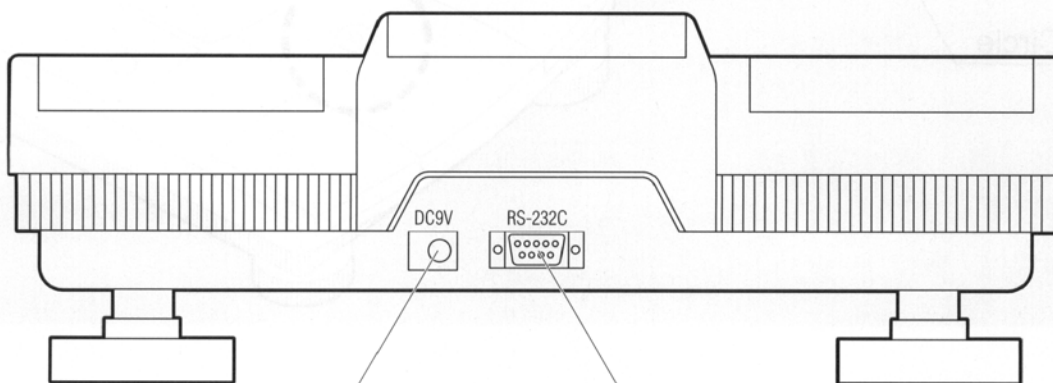

DC Jack

RS-232C Port

# 5. Set Up



## Power Supply

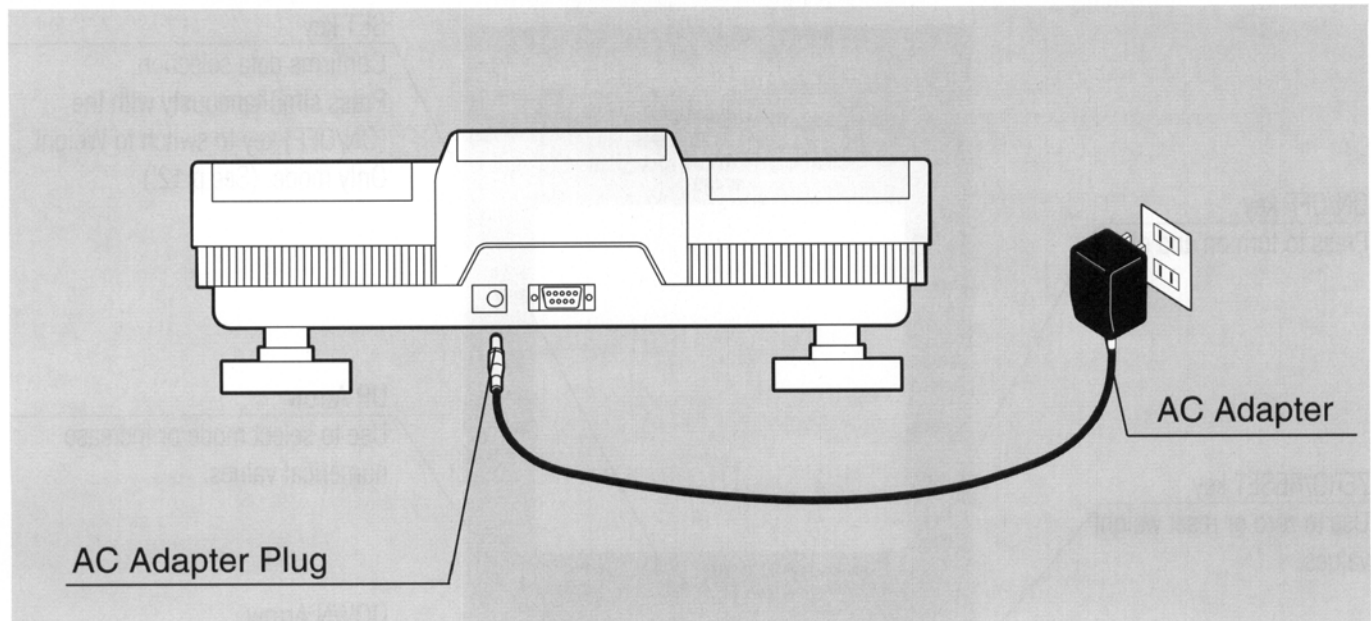

1. Insert the AC adapter plug into the DC jack in the rear of the unit.
2. Plug the AC adapter into an AC outlet.

 **WARNING** To reduce the risk of electric shock, never insert or remove the plug with wet hands.

 **CAUTION** Use only the Tanita AC adapter provided. Use of other AC adapters may cause smoke or fire.

NOTE: The AC adapter included with this product has a built-in converter and can handle either 110V or 220V systems.

## Leveling the Weighing Platform

If used on an uneven surface, feet may be adjusted to ensure a level and stable platform.

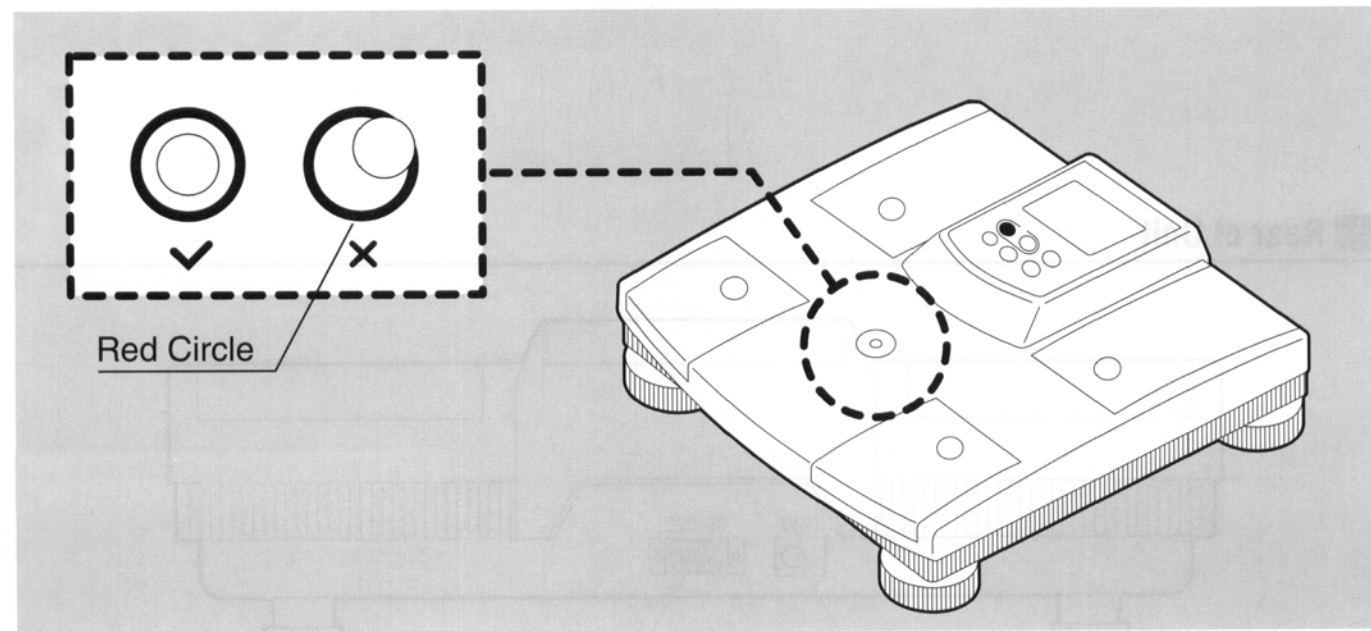



# 6. Operating Instructions

## The BF-350 can be used in two ways:

As a "stand alone" unit where data is entered on the platform keypad and displayed on the Display.

OR

Linked to a PC using Tanita's Software. This enables PC-based data entry and capture. (See P. 14)

## OPERATING THE BF-350 AS A "STAND ALONE" UNIT

After setting up the unit (page 8), use the keypad located on the scale platform to enter data.

## Body Composition Analysis (Body Fat Mode) NOTE: This unit is factory pre-set to always start up in Body Fat Mode.

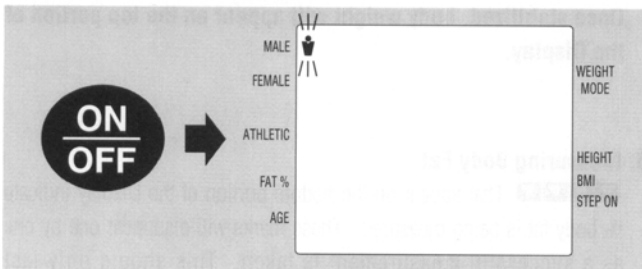

### 1. Press the [ON/OFF] key to turn the unit on.

The entire display will flash for a few seconds, and then the "♂" gender symbol will flash.

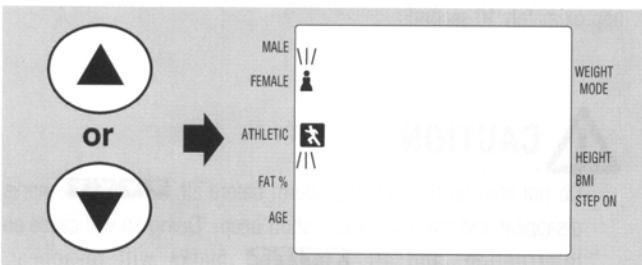

### 2. Gender and Body Type Input

Select the appropriate Gender and Body Type icon by using the (ARROW KEYS). Press the SET key to confirm selection.

- ♂ : Standard Male.
- ♀ : Standard Female.
- ♂ ⚡ : Male Athlete.
- ♀ ⚡ : Female Athlete.

## CAUTION

\*The following individuals should use Athlete Mode:

- Individuals over the age of 16 who exercise at least 10 hours a week, consistently for a period of at least 6 months.
- Individuals who have a resting heart rate of approximately 60 beats per minute or less.
- This mode includes people who have been very fit for years but currently exercise less than 10 hours per week.

\* For more information regarding Athlete Mode, please see the Technical Notes.

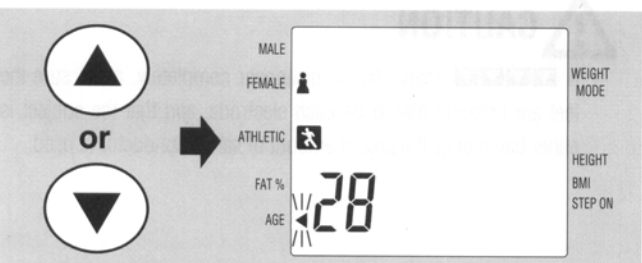

### 3. Age Input

Press and hold (▲▼) to scroll up or down to the desired age. Press SET to confirm the selection.

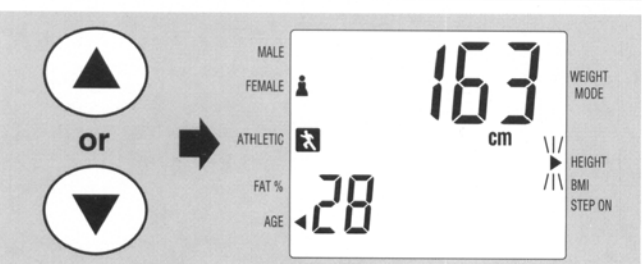

### 4. Height Input

\* Press the kg./lb. key at this time to change measurement settings. Press and hold (▲▼) to scroll up or down to the desired height. Press SET to confirm the selection.

## CAUTION

If a mistake is made during data entry, simply turn the unit off, and return to Step 1.

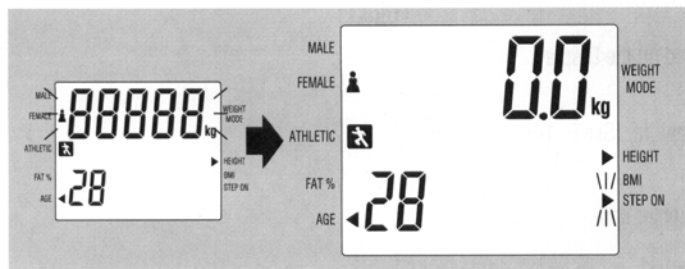

**5. When the ► cursor next to "STEP ON" flashes, step onto the weighing platform.**

Stand with both feet flat on the surface of the electrodes. Make sure your feet are positioned across the anterior electrodes and posterior electrodes. Face forward, stand still and do not bend your knees.

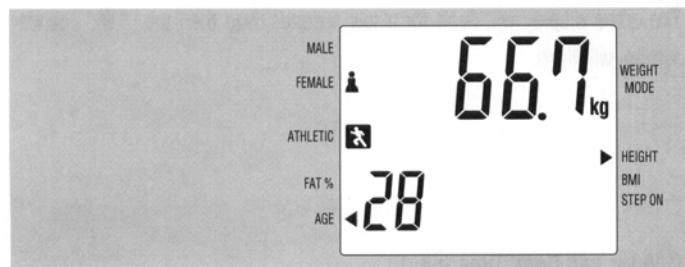

**Once stabilized, body weight will appear on the top portion of the Display.**

**6. Measuring Body Fat**

▣▣▣▣ That appear on the bottom portion of the Display indicate % body fat is being measured. These marks will disappear one by one as a successful measurement is taken. This should only last approximately 10 seconds.

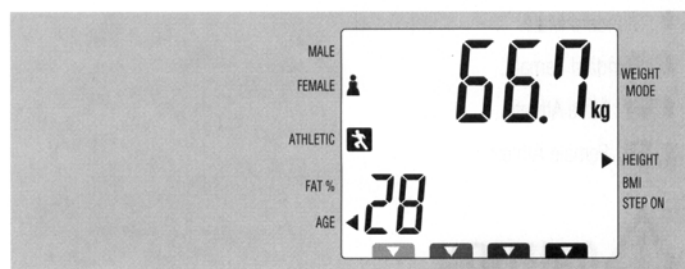

**CAUTION**

Do not step off the weight platform before all ▣▣▣▣ marks disappear and the unit emits a short beep. Doing so will cause an interruption, and all ▣▣▣▣ marks will re-appear. (Measurement may be continued if test subject steps back on immediately).

**CAUTION**

Stand as still as possible on the weighing platform. If the measurement values remain unstable beyond a certain length of time, error message "E-16" will be displayed, and the unit will automatically turn off. If this occurs, turn the unit back on, and return to Step 2.

**CAUTION**

If ▣▣▣▣ marks fail to disappear completely, make sure the feet are properly placed on each electrode, and that the subject is either barefoot or the proper amount of saline conductor is used.

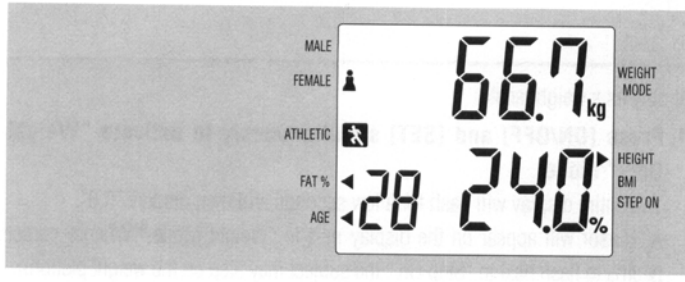

**7. Results**

The unit will emit a short beep, at which time the subject may step carefully off the weighing platform. Weight will appear on the top portion of the Display, while % body fat appears on the lower half. These results will remain on the display for approximately 30 seconds.

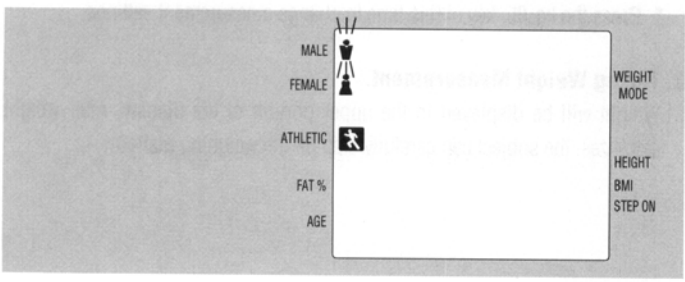

**8. Continuing Measurement**

The scale automatically resets itself after approximately 30 seconds. Press any key (other than ON/OFF) to reset the scale before 30 seconds. To test a new subject, return to Step 2.

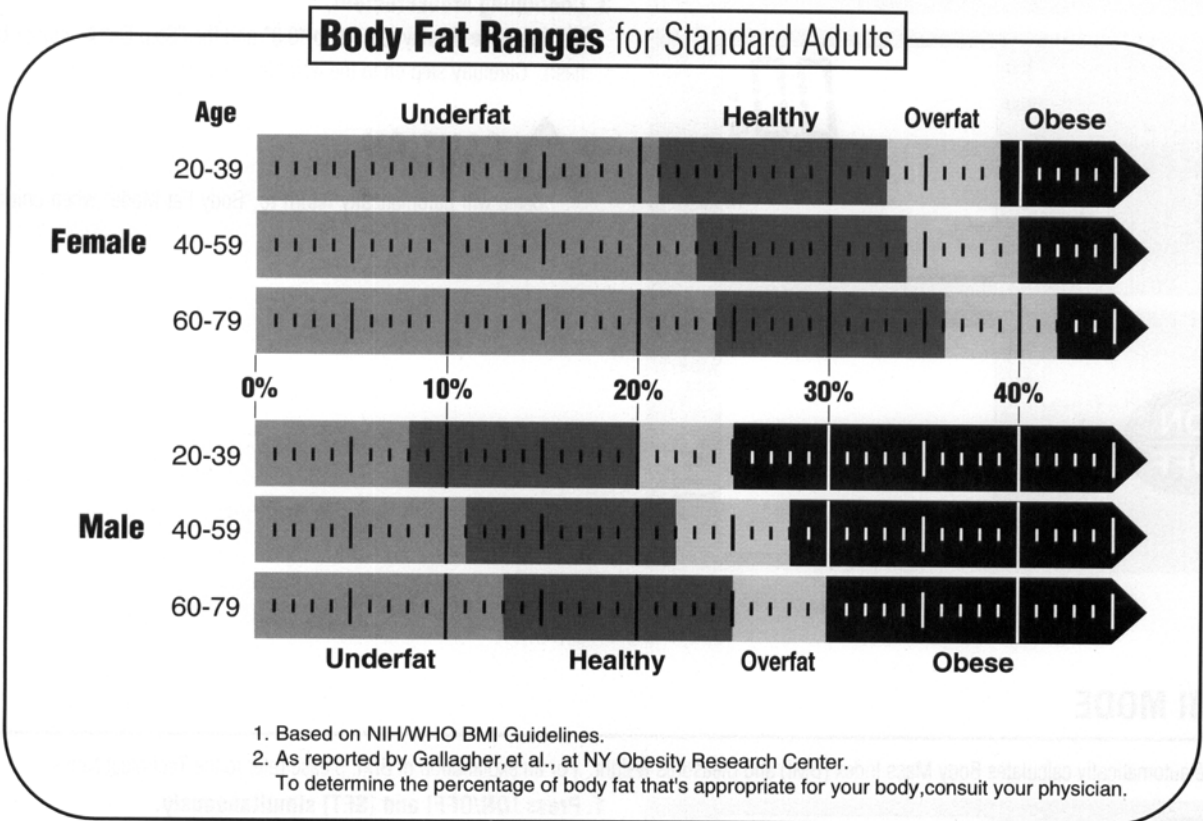



## WEIGHT ONLY MODE

It is possible to deactivate the % body fat function of the BF-350, and use the unit only as a weight scale.

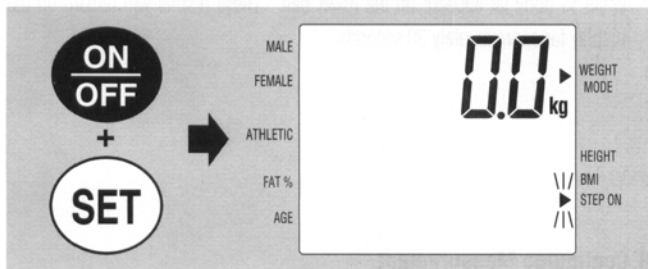

### 1. Press [ON/OFF] and [SET] simultaneously to activate "Weight Only" Mode.

The entire display will flash for a few seconds and then display "0.0".

A cursor will appear on the display next to "Weight Mode." When a cursor begins to flash next to "Step On," the subject may step on the weight platform.

\* A minus sign may appear when the [ON/OFF] and [SET] keys are released.

If this happens, press [ZERO/RESET] to display "0.0" again.

\* Press the kg./lb. key at this time to change measurement settings.

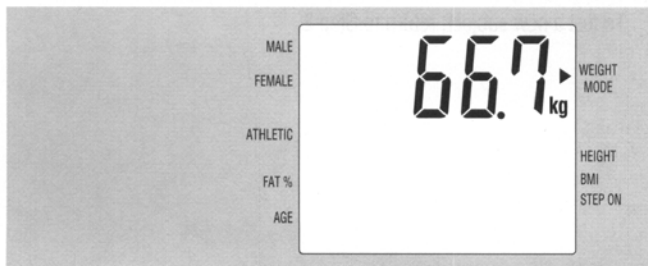

### 2. Taking Weight Measurement.

Weight will be displayed in the upper portion of the display. After weight stabilizes, the subject can carefully step off the weighing platform.

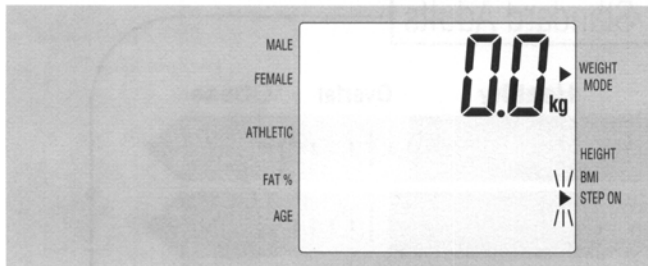

### 3. Continuing Measurement.

Wait until the display returns to "0.0" and the "Step On" ► cursor begins to flash. Carefully step on to the weighing platform.



### CAUTION

Scale will automatically return to "Body Fat Mode" when unit is turned off.

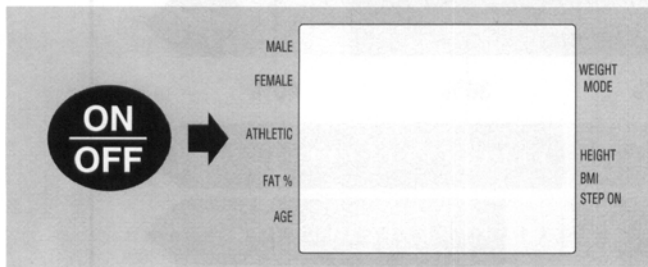

## BMI MODE

This mode automatically calculates Body Mass Index (BMI) and measures weight. For an explanation of BMI, please refer to the Technical Notes.

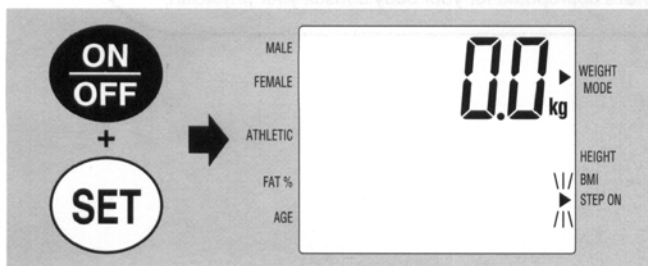

### 1. Press [ON/OFF] and [SET] simultaneously.

The entire display will flash for a few seconds, and then display "0.0" ►.cursor will appear on the Display next to "Weight Mode," and the "Step On" ► cursor will flash.

\* A minus sign may appear when the [ON/OFF] and [SET] keys are released.

If this happens, press [ZERO/RESET] to display "0.0" again.

\* Press the kg./lb. key at this time to change measurement settings.

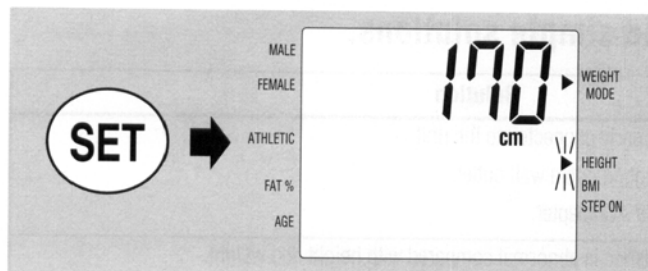

**2. To activate BMI Mode, press the SET key once more.**  
 A default height setting will appear in either Ft/In. or cm.  
 Press the kg./lb. key at this time to change measurement settings.

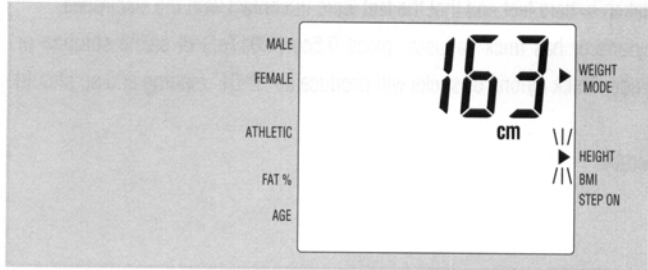

**3. Height Input.**  
 \*Press and hold arrow keys to scroll to the desired height.  
 \*Press SET to confirm setting.

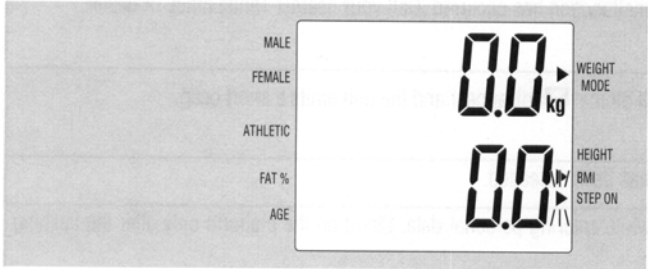

The display will then show "0.0". One cursor will flash on the Display next to BMI, and another will flash next to "Step On."

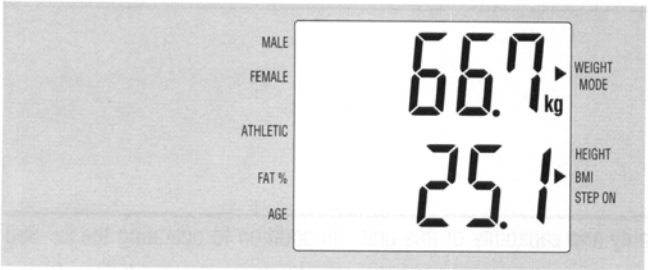

**4. Measuring BMI**  
 \* When the ► cursor next to "Step On" flashes, carefully step on to the weighing platform.  
 \* Weight will appear on the upper portion of the Display, BMI appears on the lower portion.  
 \* Results will disappear when the subject steps off the scale.

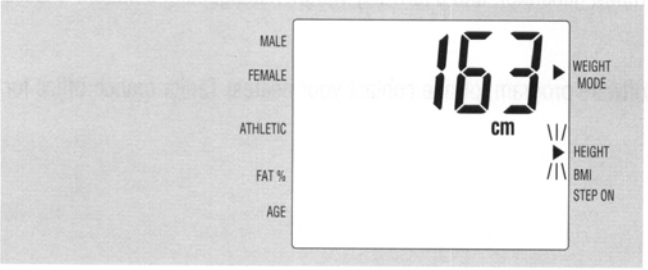

**5. Continuing BMI Measurement**  
 Press the SET key twice  
 Return to Step 3, "Height Input."  
 \* To return to "Weight Only" Mode: Press the SET key once.  
 \* To return to "Body Fat" Mode: Turn the unit off and back on using the ON/OFF key.

# 7. Troubleshooting

GB

■ Listed below are some common problems and simple solutions.

Problem	Solution
Unit does not switch on when the [ON/OFF] key is pressed.	<ul style="list-style-type: none"><li>• Check that the AC adapter is properly connected to the unit.</li><li>• Make sure the AC adapter is plugged into a wall outlet.</li><li>• Make sure you are using a Tanita AC adapter.</li></ul>
"E-01" is shown.	<ul style="list-style-type: none"><li>• "E-01" is displayed when impedance is abnormal compared with height and weight.</li><li>• Make sure measurements were taken in bare feet and that the feet were in contact with the electrodes.</li><li>• If the subject is wearing thin nylons or has thick calluses, place 0.5cc (0.017oz) of saline solution or water in the center of each electrode. Thick nylons or socks will produce an "E-01" reading and so should be removed.</li><li>• Check the personal data for accuracy.</li></ul>
"E-11/12/13/14" are shown.	<ul style="list-style-type: none"><li>• These appear when an internal malfunction has occurred. Call your nearest Tanita office or dealer.</li></ul>
"E-16" is shown.	<ul style="list-style-type: none"><li>• Do not step off the platform until all the <input checked="" type="checkbox"/> disappear and the unit emits a short beep.</li></ul>
"-----" is shown.	<ul style="list-style-type: none"><li>• The maximum weight capacity has been exceeded.</li></ul>
"E-17" is shown.	<ul style="list-style-type: none"><li>• Do not step onto the platform while entering personal data. Stand on the platform only after the flashing arrow appears next to "Step On".</li></ul>

## 8. Optional Software –

Tanita Corporation has software available that greatly enhances the functionality and capability of this unit. In addition to operating the BF-350 from a remote computer keyboard, Tanita's software acts as a client database, report generator, and a turn-key weight management solution. Please contact your nearest Tanita dealer for more information.

If your facility wishes to incorporate the BF-350 into an existing interactive software program, please contact your nearest Tanita branch office for RS-232 communication protocol and transmission specification.



This device features radio interference suppression in compliance with valid EC Regulation 89/336/EEC.



#### FEDERAL COMMUNICATIONS COMMISSION NOTICE

This equipment has been tested and found to comply with the limits for a Class B digital device, pursuant to Part 15 of the FCC Rules. These limits are designed to provide reasonable protection against harmful interference in a residential installation. This equipment generates, uses and can radiate radio frequency energy and, if not installed and used in accordance with the instructions, may cause harmful interference to radio communications. However, there is no guarantee that interference will not occur in a particular installation. If this equipment does cause harmful interference to radio or television reception, which can be determined by turning the equipment on and off, the user is encouraged to try to correct the interference by one or more of the following measures:

- Reorient or relocate the receiving antenna.
- Increase the distance between the equipment and receiver.
- Connect the equipment into an outlet on a circuit different from that to which the receiver is connected.
- Consult the dealer or an experienced radio or television technician for help.

#### Modifications

The FCC requires the user to be notified that any changes or modifications made to this device that are not expressly approved by Tanita Corporation may void the user's authority to operate the equipment.

# TANITA

#### TANITA Corporation

14-2,1-chome, Maeno-cho, Itabashi-ku  
Tokyo, Japan  
Tel: (03)3968-2123 / (03)3968-7048 Fax: (03)3967-3766

#### TANITA Corporation of America, inc.

2625 South Clearbrook Drive  
Arlington Heights, Illinois 60005 U.S.A.  
Toll Free : (800) 826-4828  
Tel : 847-640-9241  
Fax : 847-640-9261  
<http://www.tanita.com>

#### TANITA Health Equipment H.K.LTD.

Unit 301-303 3/F Wing On Plaza,  
62 Mody Road, Tsimshatsui East,  
Kowloon, Hong Kong  
Tel : +852-2838-7111  
Fax : +852-2838-8667

#### TANITA Europe GmbH

Dresdener Strasse 25  
D-71065 Sindelfingen,  
Germany  
Tel : 07031-6189-6  
Fax : 07031-6189-71

#### TANITA UK LTD.

The Barn, Philpots Close,  
Yiewsley, West Drayton,  
Middlesex, UB7 7RY,  
United Kingdom  
Tel : +44-1895-438577  
Fax : +44-1895-438511

#### TANITA France S.A.

Villa Labrouste  
68 Boulevard Bourdon,  
92200 Neuilly-Sur-Seine,  
France  
Tel : 01 55 24 99 99  
Fax : 01 55 24 98 68